

## 30V<sub>DS</sub>/±20V<sub>GS</sub> N-Channel MOSFET

### General Description

These N-Channel enhancement mode power field effect transistors are using SGT technology. This advanced technology has been especially tailored to minimize on-state resistance, provide superior switching performance, and withstand high energy pulse in the avalanche and commutation mode.

### Features

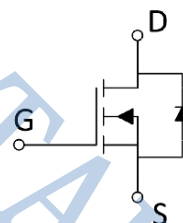
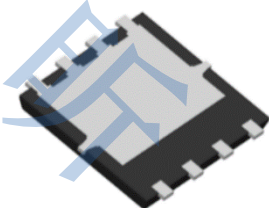
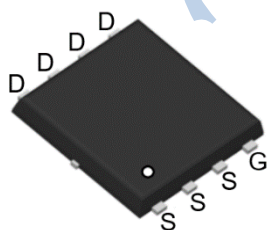
<b>BVDSS</b>	<b>30V</b>
<b>R<sub>DS(ON)</sub>(10V)</b>	<b>3.9mΩ (TYP)</b>
<b>R<sub>DS(ON)</sub>(4.5V)</b>	<b>6.0mΩ (TYP)</b>
<b>I<sub>D</sub></b>	<b>80A</b>

100% UIS TESTED!

100% ΔV<sub>ds</sub> TESTED!



PDFN5060



### Absolute maximum ratings (T<sub>A</sub>=25°C)

Symbol	Parameter	Value	Unit
V <sub>DS</sub>	Drain-Source Voltage	30	V
V <sub>GS</sub>	Gate-Source Voltage	±20	V
I <sub>D</sub>	Continuous Drain Current (T <sub>C</sub> =25°C)	80	A
	Continuous Drain Current (T <sub>C</sub> =100°C)	50	A
I <sub>DM</sub>	Pulsed Drain Current	200	A
I <sub>AS</sub>	Avalanche Current (L=0.1mH)	31	A
E <sub>AS</sub>	Single Pulsed Avalanche Energy	48	mJ
P <sub>D</sub>	Maximum Power Dissipation (T <sub>C</sub> =25°C)	59	W
	Maximum Power Dissipation (T <sub>C</sub> =100°C)	23	W
T <sub>J</sub> , T <sub>STG</sub>	Operating, Storage Temperature Range	-55~150	°C

### Thermal Characteristics

Symbol	Parameter	Typ.	Max.	Unit
R <sub>θJC</sub>	Thermal Resistance, Junction-to-Case	2.1	---	°C/W
R <sub>θJA</sub>	Thermal Resistance, Junction-to-Ambient	55	---	°C/W

**Electrical Characteristics** ( $T_J=25^{\circ}\text{C}$ , unless otherwise noted)

**Static State Characteristics**

Symbol	Parameter	Test Conditions	Min.	Typ.	Max.	Unit
$B_{VDSS}$	Drain-Source Breakdown Voltage	$V_{GS}=0V, I_D=250\mu A$	30	---	---	V
$I_{DSS}$	Zero Gate Voltage Drain Current	$V_{DS}=30V, V_{GS}=0V$	---	---	1	$\mu A$
$I_{GSS}$	Gate -Source Leakage Current	$V_{GS}=\pm 20V, V_{DS}=0V$	---	---	$\pm 100$	nA
$V_{GS(th)}$	Gate Threshold Voltage	$V_{DS}=V_{GS}, I_D=250\mu A$	1.1	1.5	1.9	V
$R_{DS(ON)}$	Drain-Source On-stage Resistance	$V_{GS}=10V, I_D=20A$	---	3.9	5.0	m $\Omega$
		$V_{GS}=4.5V, I_D=20A$	---	6.0	7.5	

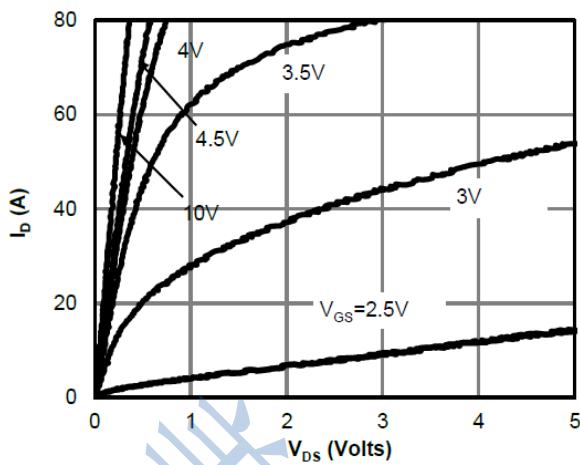
**Dynamic Characteristics**

Symbol	Parameter	Test Conditions	Min.	Typ.	Max.	Unit
$C_{iss}$	Input capacitance	$V_{DS}=15V$ $V_{GS}=0V$ $f=1MHz$	---	1062	---	pF
$C_{oss}$	Output capacitance		---	275	---	
$C_{rss}$	Reverse transfer capacitance		---	21	---	
$R_g$	Gate Resistance	$f=1MHz$	---	1.1	---	$\Omega$
$Q_g$	Total Gate Charge	$V_{DS}=15V$ $V_{GS}=10V$ $I_D=20A$	---	12	---	nC
$Q_{gs}$	Gate Source Charge		---	3.7	---	
$Q_{gd}$	Gate Drain Charge		---	1.8	---	
$t_{d(on)}$	Turn-on delay Time	$V_{DS}=15V$ $V_{GS}=10V$ $R_G=3\Omega$ $I_D=20A$	---	6.3	---	ns
$t_r$	Rise time		---	3.5	---	
$t_{d(off)}$	Turn-off delay Time		---	24	---	
$t_f$	Fall time		---	4.1	---	
$V_{SD}$	Diode Forward Voltage	$V_{GS}=0V, I_{SD}=10A$	---	0.7	1.2	V
$t_{rr}$	Reverse Recovery Time	$I_D=20A$ $d_i/d_t=100A/\mu s$	---	12	---	ns
$Q_{rr}$	Reverse Recovery Charge		---	20	---	nC

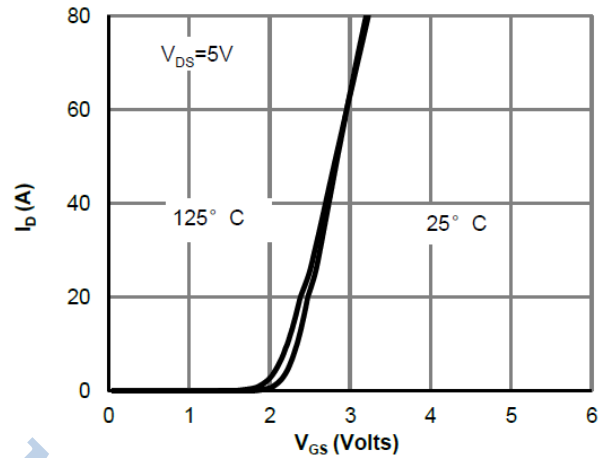
**Note:**

- 1.Repetitive Rating : Pulsed width limited by maximum junction temperature.
- 2.The data tested by pulsed , pulse width  $\leq 300\mu s$  , duty cycle  $\leq 2\%$ .
- 3.Essentially independent of operating temperature.

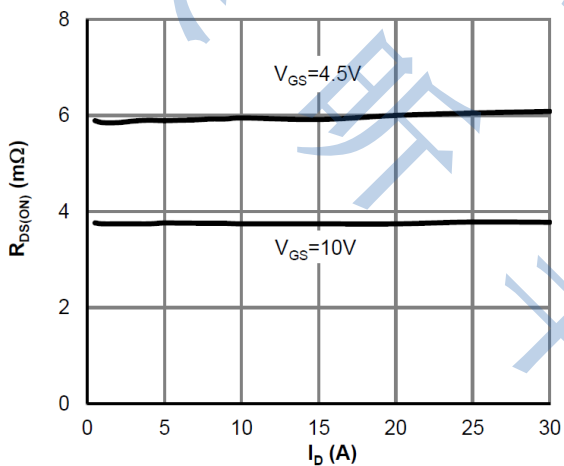
## Electrical Characteristics Diagrams



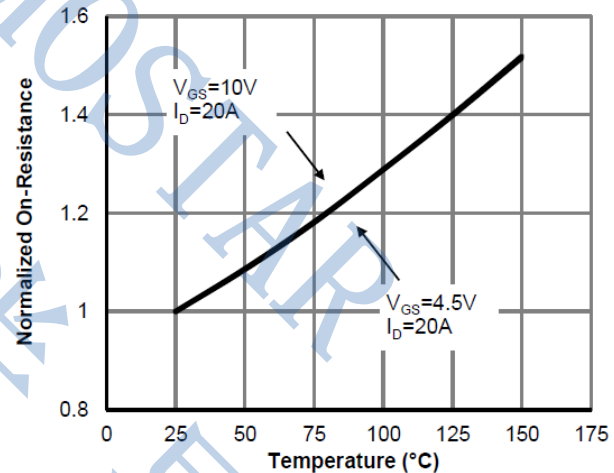
**Figure 1. On-Region Characteristics**



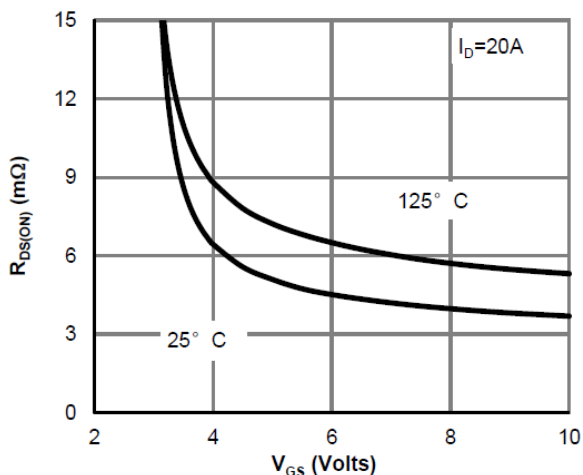
**Figure 2. Transfer Characteristics**



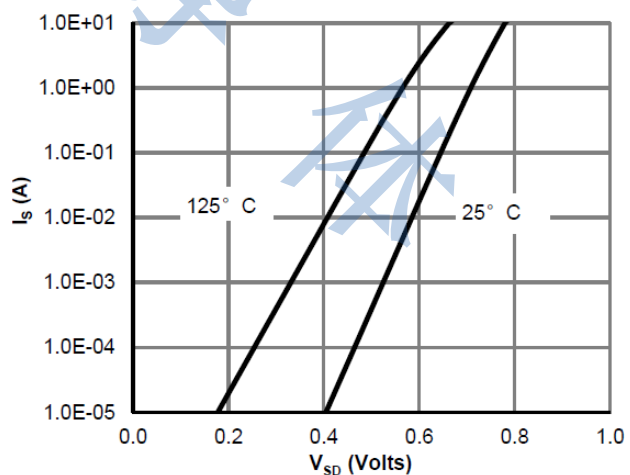
**Figure 3.  $R_{DS(ON)}$  vs.  $I_D$  and Gate Voltage**



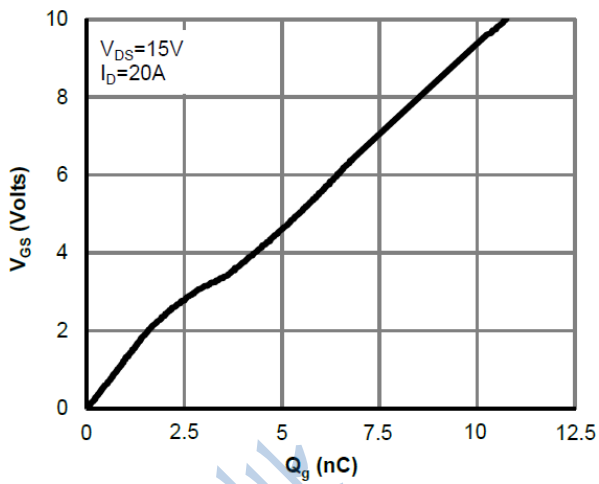
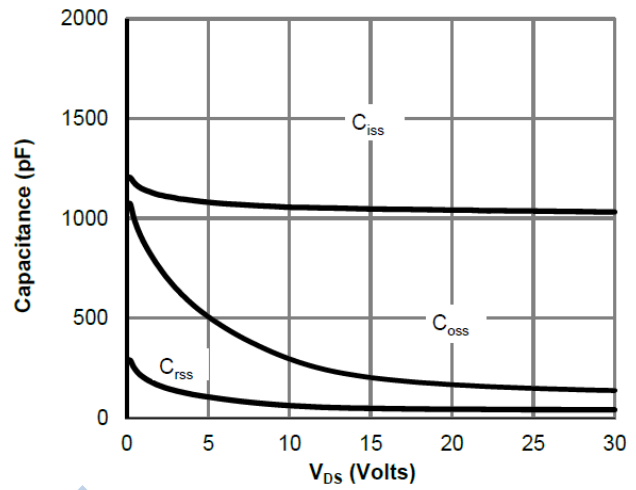
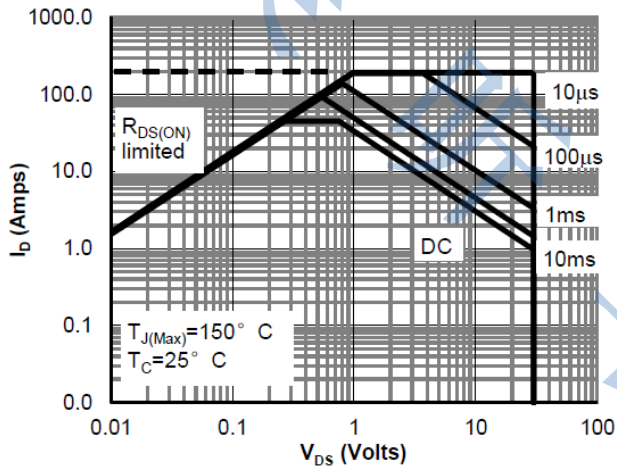
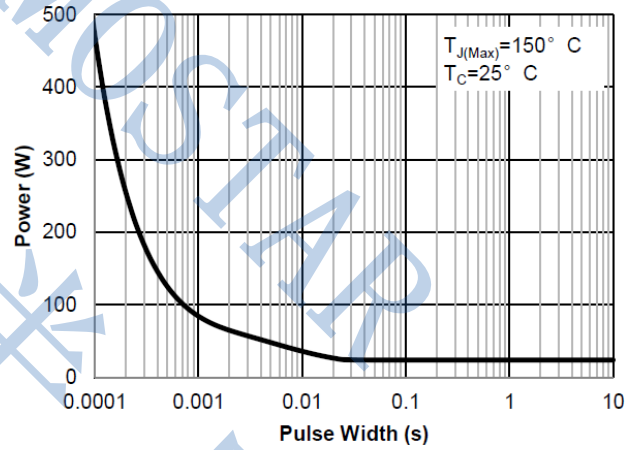
**Figure 4.  $R_{DS(ON)}$  vs. Junction Temperature**

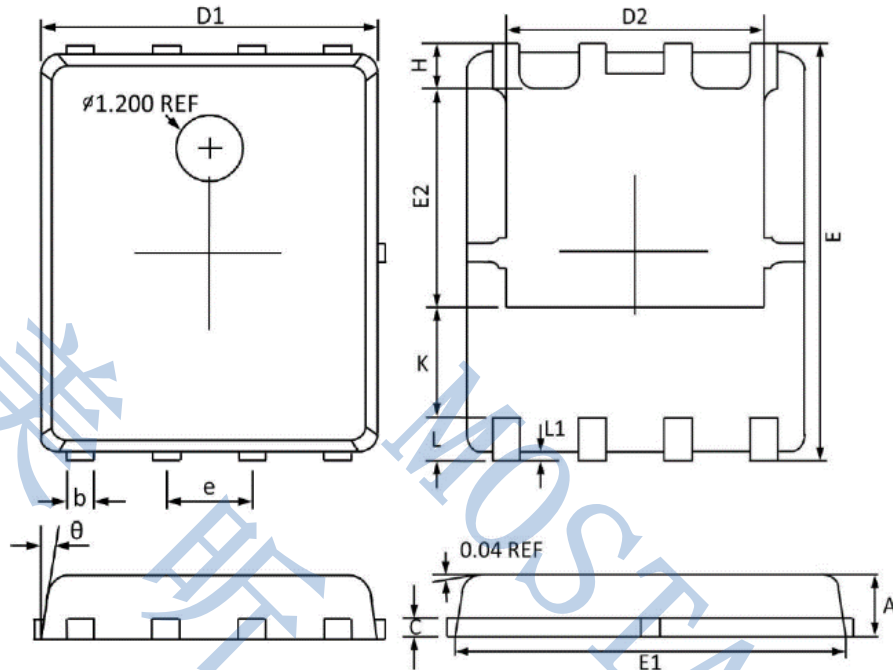


**Figure 5.  $R_{DS(ON)}$  vs. Gate Voltage**



**Figure 6. Body-Diode Characteristics**


**Figure 7. Gate-Charge Characteristics**

**Figure 8. Capacitance Characteristics**

**Figure 9. Safe Operating Area**

**Figure 10. Single Pulse Power Rating  
Junction-to-Ambient**

**PDFN5060 PACKAGE INFORMATION**


Symbol	Dimensions In Millimeters(mm)	
	MIN	MAX
A	0.800	1.100
b	0.330	0.510
C	0.200	0.300
D1	4.800	5.100
D2	3.610	4.100
E	5.900	6.200
E1	5.700	5.900
E2	3.350	3.780
e	1.27BSC	
H	0.410	0.700
K	1.100	1.500
L	0.510	0.710
L1	0.060	0.200
$\theta$	0°	12°